

# Integrated ceiling evaporator heater ARCTIC



The ARCTIC ceiling evaporator heating system is designed to fit into the false ceiling in cab roofs in public works equipment and farm machinery such as combined harvesters, loaders, etc.

The ARCTIC can be delivered fitted with a cable-controlled heating valve, 2 rectangular air louvers and a 3-button control panel.

- Three-speed fan selector
- Heating valve mechanical control
- Mechanical control for the air conditioning thermostat

The ARCTIC unit, available in black, can be fitted with an optimal air filter.

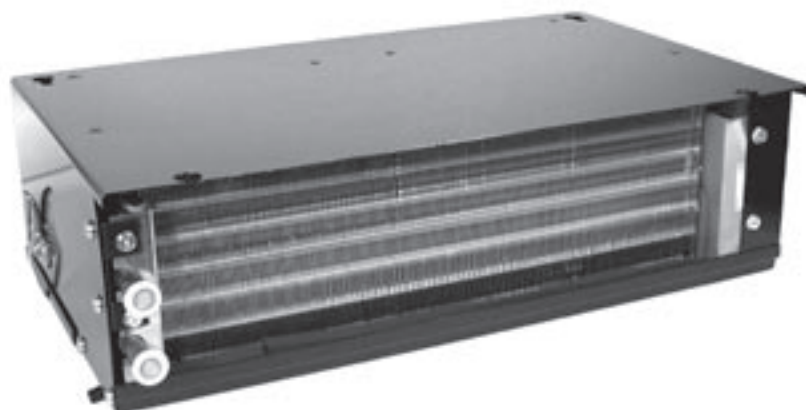

**ARCTIC B :** Evaporateur seul

**ARCTIC Combi :** Evaporateur chauffage

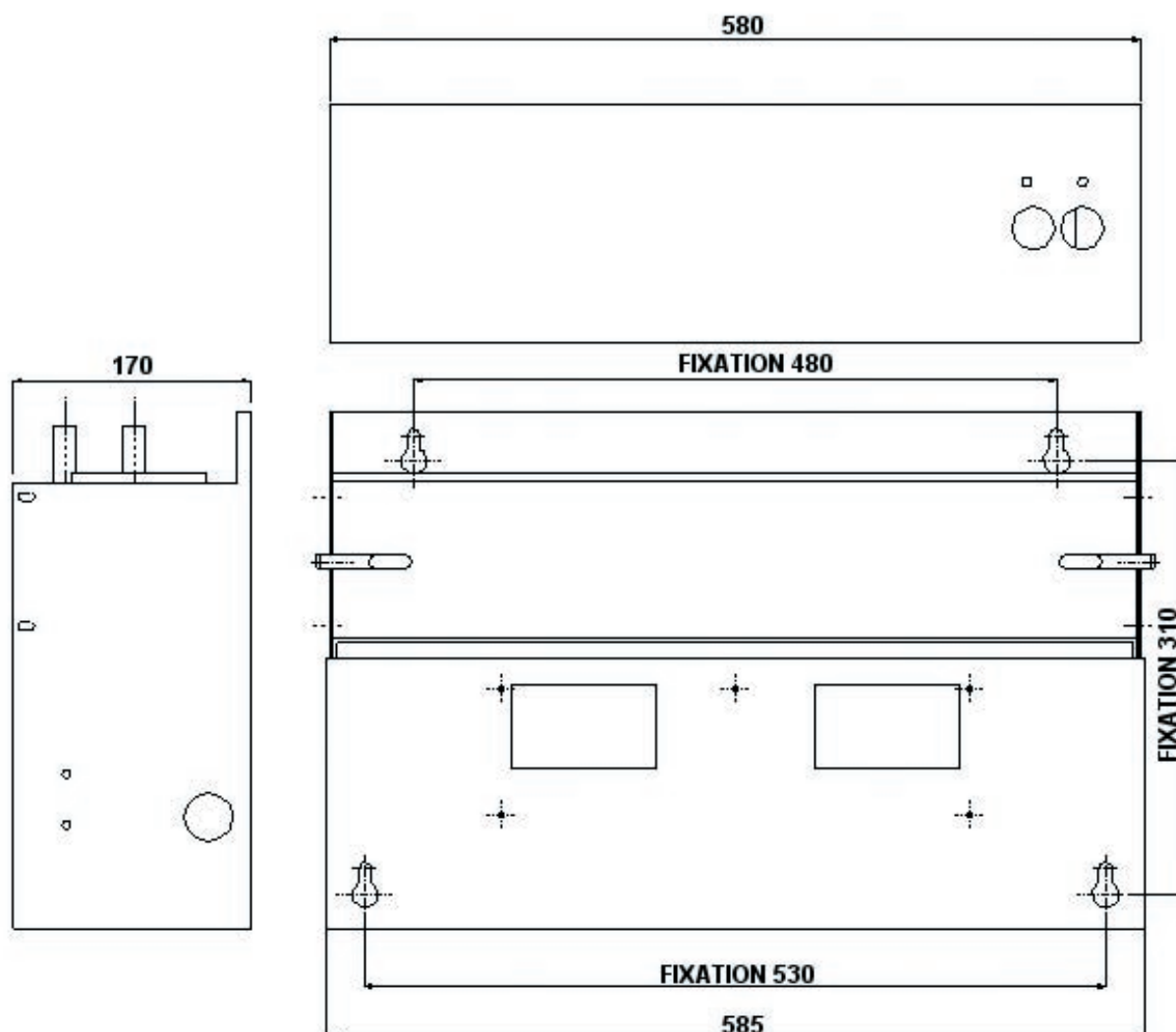



## OPTION

### CONTROL PANEL



### HEATER VALVE



### AIR FILTER OPTION

- Composition :
- EU5-F5 air filter
  - Filter support
  - Holding tab



## PART NUMBERS

P/N		Voltage	
ARCTIC B	ARTIC COMBI	12V	24V
350B58	350A03	•	
350A08	350A04		•

## TECHNICAL SPECIFICATIONS

A/C performance	6,5 KW IMACA Standard 200
Heating Performance	11,5 Kw
Maximum air flow	1090 m <sup>3</sup> /h
Electrical power	411 W
Weight	12 Kg